



# PMC-53A-E

## Ethernet Multifunction Meter



# Ethernet



**PMC-53A-E** Ethernet Multifunction Meter is CET's latest offer for the digital power/energy metering market. Housed in a standard DIN form factor measuring 96x96x83.6mm, it is perfectly suited for industrial, commercial and utility applications requiring direct Ethernet connectivity. The PMC-53A-E features quality construction, multifunction measurements and a large, backlit, Dot-Matrix LCD that is easy to navigate and user friendly. Compliance with the IEC 62053-22 Class 0.2S\*/0.5S and ANSI C12.1 Class 0.2, it is a cost-effective replacement for analog instrumentation and is capable of displaying 4 measurements at once. It also optionally provides an I4 input for Neutral Current Measurement, one 0/4-20mA Analog Input for measuring external transducer signals as well as an Ir Input for Residual Current Measurement. With a standard 10Base-T/100Base-TX Ethernet Port and an RS-485 port supporting multiple protocols, the PMC-53A-E can be easily integrated into Energy Management Systems as well as Building and Utility Automation Systems.

## Typical Applications

- Industrial, Commercial and Utility Substation Metering
- Building, Factory and Process Automation
- Sub-metering and Cost Allocation
- Retrofit applications with Split-Core Current Transformers and Rogowski Coils\*

## Features Summary

### Basic Measurements

- ULN, ULL per Phase and Average with Neutral-to-Ground Voltage (Ung)
- Current per Phase and Average with calculated Neutral
- P, Q, S, PF per Phase and Total
- kWh, kvarh Import/Export/Net/Total and kVAh Total
- Frequency
- Device Operating Time (Running Hours)
- Optional Neutral Current (I4) and Residual Current (Ir) Measurement

### Advanced Measurements

- 1-cycle Real-time U & I Waveform Display @ 1s update
- U and I THD, TOHD, TEHD and Harmonics analysis up to 63<sup>rd</sup>
- Current TDD, TDD Odd, TDD Even, K-Factor and Crest Factor
- U and I Phase Angle
- Displacement PF
- Fundamental U, I and P per phase
- Total Fundamental P & Total Harmonic P
- U and I Unbalance and Sequence
- ULN, ULL Over/Under Deviation and Frequency Deviation\*
- %kvarh Imp./kWh Imp., %kvarh Exp./kWh Imp. for Last Day & Last 30 Days
- Interval Energy for kWh/kvarh Imp./Exp. and kVAh
- Present, Predicted and Max. Demands for ULN, ULL, I per phase and Average as well as P, Q, S Total with Timestamp for This Month & Last Month (or Since Last Reset & Before Last Reset)
- Two TOU schedules, each providing
  - 12 Seasons\*
  - 20 Daily Profiles, each with 12 Periods\*
  - 90 Holidays or Alternate Days
  - 8 Tariffs, each providing the following information
    - Total and 3-phase kWh/kvarh Imp./Exp., kVAh
    - P, Q, S Max. Demands
    - 12 Monthly Logs of kWh, kvarh Imp./Exp./Tot./Net, kVAh and kvarh Q1-Q4 as well as kWh/kvarh Imp./Exp., and kVAh per Tariff

### Ease of use

- Large, backlit, Dot-Matrix LCD display with wide viewing angle
- Intuitive user interface
- LED indicators for Energy Pulsing and Communication activities
- Password protected setup via Front Panel, Web Server or free software
- Easy installation with mounting clips, no tools required

### SOE Logs

- 100 events time-stamped to  $\pm 1$ ms resolution
- Setup changes, Setpoint, DI status changes and DO operations

### Max./Min. Log

- Max./Min. Log with Timestamp for Real-time measurements such as Voltage, Current, In, I4, Ir, Freq., P, Q, S, PF, Unbalance, K-Factor, Crest Factor and THD
- Configurable for This Month & Last Month (or Since Last Reset & Before Last Reset)

### Freeze Logs

- 60 Daily Freeze Logs for kWh/kvarh/kVAh Total and P/Q/S Max. Demands
- 36 Monthly Freeze Logs for kWh/kvarh/kVAh Total and P/Q/S Max. Demands with Timestamp

### Data Recorder (DR)

- 5 Data Recorders of 16 parameters\* each for Real-time measurements, Harmonics, Energy, Demand, TOU, Pulse Counters, etc.
- Recording interval from 1 minute to 40 days
- Configurable capacity up to a max. of 1,250\* days (> 3 years) at 15-minute interval for 1 Data Recorder with 16 parameters for **HK BEC 2021 Compliant Recording**

\*These features are upgraded in the PMC-53A-E V2 and later versions.

# PMC-53A-E



## Setpoints

- 9 user programmable setpoints with extensive monitoring parameters including Voltage, Current, Power, PF, Current and Power Demand, Unbalance and THD, etc.
- Configurable thresholds, time delays, DO and Alarm Email triggers

## Diagnostics

- Frequency Out-of-Range, Loss of Voltage/Current
- P Direction per Phase and Total, Possible incorrect CT Polarity
- Incorrect U & I Phase Sequence
- Disconnection of Residual Current Input

## Communications

- 1x10Base-T/100Base-TX Ethernet Port with RJ45 connector
- 1xOptically isolated RS-485 port with baud rate from 1.2kbps to 38.4kbps
- Built-in Web Server for easy data viewing and setup configurations
- Protocol supported: Modbus TCP/RTU, BACnet MS/TP, DNP 3.0, HTTP, SMTP, SNMP, TFTP and Ethernet Gateway

## Real-Time Clock

- Battery-backed Real-time Clock with 6ppm accuracy (<0.5s per day)

## System Integration

- Supported by CET's PecStar® iEMS
- Easy integration into Building Automation Systems with BACnet MS/TP or Modbus RTU and Utility Substation Automation with DNP 3.0
- The on-board password protected Web Server allows complete access to its data and supports the configuration for most of the Setup parameters via a standard web browser

## Inputs and Outputs

### Digital Outputs

- 2 Form A Mechanical Relays for alarming and general purpose control

### Digital Inputs

- 4 channels, volt free dry contact, 24VDC internally wetted
- 1000Hz sampling for status monitoring with programmable debounce
- Pulse counting with programmable weight for each channel for collecting WAGES (Water, Air, Gas, Electricity, Steam) information
- Tariff switching based on DI status

### Pulse Outputs (Optional)

- 2 Form A Solid State Relays for kWh and kvarh pulsing

### Analog Inputs (Optional)

- I4 Current Input for Neutral Current measurement
- Ir Input for Residual Current measurement (CT not included)
- 0/4-20mA DC input with programmable zero and full scales

## Accuracy

Parameters	Accuracy			Resolution
	5A/1A Input		SCCT/RC Input	
	Class 0.2S	Class 0.5S		
Voltage	±0.1%	±0.2%	±0.5%	0.001V
Current	±0.1%	±0.2%	±0.5%	0.001A
I4 Input	±0.1%	±0.2%	±0.5%	0.001A
P, Q, S	±0.2%	±0.5%	±1%	0.001kX
kWh, kVAh	IEC 62053-22 Class 0.2S/ IEC 62053-22 Class 0.5S ANSI C12.1 Class 0.2		IEC 62053-21 Class 1	0.1kXh
kvarh	IEC 62053-24 Class 0.5S IEC 62053-23 Class 2		IEC 62053-24 Class 1 IEC 62053-23 Class 2	0.1kvarh
Frequency	±0.01Hz	±0.02Hz	±0.02Hz	0.01Hz
PF	±0.2%	±0.5%	±1%	0.001
Ir Input	±0.5%			0.001A
THD	IEC 61000-4-7 Class II			0.001%
K-Factor	IEC 61000-4-7 Class II			0.001
Phase Angle	±1°			0.1°

# Multifunction

## Technical Specifications

Voltage Inputs (V1, V2, V3, VN)	
Standard Un	400VLN/690VLL
Range	10V to 2xUn
Overload	2xUn continuous, 5xUn for 1s
Burden	<0.02VA per phase
Measurement Category	CAT III 600V
Frequency	45-65Hz

Current Inputs (-I11, I12, -I21, I22, -I31, I32, Optional -I41, I42)	
Standard In	5A (Optional 1A)
Burden	<0.15VA per phase @ 5A
Range	0.1% to 200% In
Starting Current	0.1% In
Overload	2xIn continuous, 20xIn for 1s
SCCT Options	100A/200A/400A/800A/1600A to 40mA
Rogowski Coil Options	400A/1200A/2500A/5000A to 40mA

Power Supply (L/+, N/-)	
Standard	60-250VAC, ±10%, 47-440Hz 24-250VDC, ±10%
Burden	<4W
Overvoltage Category	OVC III up to 300VLN

Digital Inputs (DI1, DI2, DI3, DI4, DIC)	
Type	Dry contact, 24VDC internally wetted
Sampling	1000Hz
Hysteresis	1ms minimum

Digital Outputs (DO11, DO12, DO21, DO22)	
Type	Form A Mechanical Relay
Loading	5A @ 250VAC or 30VDC
Load Type	Resistive

Optional SS Pulse Outputs (E1+, E1-, E2+, E2-)	
Type	Form A Solid State Relay
Isolation	Optical
Load Type	Resistive
Output	Optocoupler output as ON-OFF
Max. Load Voltage	50VDC
Max. Forward Current	50mA

Optional Residual Current Input (-IR, IR)	
In	0.5mA
Range	2% to 200% In
CT Type	Solid-Core or Split-Core Residual CT

Optional Analog Input (AI+, AI-)	
Type	0-20/4-20 mA DC
Overload	24 mA DC maximum

Installation Torque	
Current Inputs	7.1 kgf.cm/M3.5/6.28 lb-in/0.7 N.m
Power Supply, Voltage Inputs, RS-485 and I/O	4 kgf.cm/M3/3.54 lb-in/0.4 N.m

Mechanical Characteristics	
Panel Cutout	92x92mm (3.62"x3.62")
Unit Dimensions	96x96x83.6mm
IP Rating	IP65 (Front Panel), IP30 (Body)

Environmental Conditions	
Operating Temperature	-25°C to 70°C
Storage Temperature	-40°C to 85°C
Humidity	5% to 95% non-condensing
Atmospheric Pressure	70 kPa to 106 kPa
Altitude	< 2000m
Pollution Degree	2
Location/Mounting	For indoor use only

## Standards of Compliance

Safety Requirements	
CE LVD 2014/35/EU	EN 61010-1: 2010 +A1: 2019 EN IEC 61010-2-030: 2021 +A11: 2021
cULus Listed	UL 61010-1, Ed.3, Rev 06/06/2023 CAN/CSA C22.2 NO. 61010-1, Ed.3 UL 61010-2-030, Ed.2 CSA C22.2 NO. 61010-2-030: 18, Ed.2
Electrical Safety in Low Voltage Distribution Systems up to 1000 Vac and 1500Vdc	IEC 61557-12: 2021 (PMD)
Insulation AC Voltage: 3.6kV @ 1 minute Insulation Resistance: >100MΩ Impulse Voltage: 6kV, 1.2/50μs	EN 61010-1: 2010 +A1: 2019 IEC 62052-31: 2015

CE EMC Directive 2014/30/EU (EN IEC 61326-1: 2021 + EN IEC 61326-2-3: 2021)	
Immunity Tests	
Electrostatic Discharge	EN 61000-4-2: 2009
Radiated Fields	EN IEC 61000-4-3: 2020
Fast Transients	EN 61000-4-4: 2012
Surges	EN 61000-4-5: 2014 +A1: 2017
Conducted Disturbances	EN 61000-4-6: 2014 +AC: 2015
Magnetic Fields	EN 61000-4-8: 2010
Voltage Dips and Interruptions	EN IEC 61000-4-11: 2020
Ring Waves	EN 61000-4-12: 2017

Emission Tests	
Limits and Methods of Measurement of Electromagnetic Disturbance Characteristics of Industrial, Scientific and Medical (ISM) Radio-Frequency Equipment	EN 55011: 2016 +A1: 2017 +A11: 2020 +A2: 2021
Electromagnetic Compatibility of Multimedia Equipment-Emission Requirements	EN 55032: 2015 +A11: 2020 +A1: 2020
Limits for Harmonic Current Emissions for Equipment with Rated Current ≤16A	EN IEC 61000-3-2: 2019 +A1: 2021
Limitation of Voltage Fluctuations and Flicker in Low-Voltage Supply Systems for Equipment with Rated Current ≤16A	EN 61000-3-3: 2013 +A1: 2019 +A2: 2021
Emission Standard for Industrial Environments	EN IEC 61000-6-4: 2019
Radiated Emissions	FCC 47CFR Part 15 Subpart B Class B ANSI C63.4: 2014
Conducted Emissions	FCC 47CFR Part 15 Subpart B Class B ANSI C63.4: 2014

Mechanical Tests	
Spring Hammer Test	IEC 62052-31: 2015
Vibration Test	IEC 62052-11: 2020
Shock Test	IEC 62052-11: 2020

BACnet Conformance Certificate	
BTL Listing	Certificate No.: BTL-31239

# Ordering Information

Product Code											Description	
PMC-53A-E Ethernet Multifunction Meter											Dot-Matrix LCD, Monthly & Daily Freeze Log, Data Recorder, 16MB Memory, 1x10Base-T/100Base-TX Ethernet Port and 1xRS-485 (Modbus RTU, BACnet MS/TP and DNP 3.0)	
Basic Function	E										5A (5A/1A Auto-Scaling)	
Input Current	5										1A	
	1											
	4 <sup>^</sup>										For use with 100A, 200A, 400A, 800A and 1600A to 40mA Split-Core CTs and 400A, 1200A, 2500A, 5000A to 40mA Rogowski Coils	
Input Voltage	9										400VLN/690VLL	
Power Supply	2										60-250 VAC ±10%, 47-440Hz, 24-250 VDC ±10%	
Frequency	5										45Hz-65Hz	
I/O	A										4xDI + 2xDO (Mechanical Relay)	
	B										4xDI + 2xSS Pulse Output	
Analog Inputs	X										None	
	A* <sup>^</sup>										I4 + AI (0/4-20mA) + Ir (0-0.5mA)	
Language	E										English	
Accuracy#	2*										Class 0,2S for Active Energy	
	""										Class 0,5S for Active Energy	
PMC-53A	-	E	-	5	9	2	5	A	X	E	2	PMC-53A-E-5925AXE2 (Class 0,2S Standard Model)
	-	E	-	5	9	2	5	A	X	E		PMC-53A-E-5925AXE (Class 0,5S Standard Model)

\* Additional charges apply

<sup>^</sup> I4 specifications of Analog Input Option A are consistent with those of the selected Input Current Option.

# The Accuracy Option represents for the accuracy of main unit. The Accuracy Option "2" is only available to Input Current Option "5" (for 5A Input) and "1". For Input Current option "4", the accuracy of main unit is Class 0,5S, excluding the accuracy of the externally connected SCCTs and Rogowski Coils.

## Accessories

### 1A/0.5mA Residual Current Sensor

CT517203	Phase Current Range: 0-160A Aperture=Ø46mm, Accuracy: Class 0.5
CT517403	Phase Current Range: 0-400A Aperture=Ø80mm, Accuracy: Class 0.5
CT519703	Phase Current Range: 0-630A Aperture=220x50mm, Accuracy: Class 0.5
CT517603	Phase Current Range: 0-1000A Aperture=Ø120mm, Accuracy: Class 0.5



CT553203	Phase Current Range: 0-160A Aperture=Ø48mm, Accuracy: Class 3
CT553303	Phase Current Range: 0-225A Aperture=Ø68mm, Accuracy: Class 3



### 1-Phase Split-Core CTs

PMC-SCCT-100A-40mA-16-A	L=2m, Aperture=Ø16mm, Accuracy: Class 0.5
PMC-SCCT-200A-40mA-24-A	L=2m, Aperture=Ø24mm, Accuracy: Class 0.5
PMC-SCCT-400A-40mA-35-A	L=2m, Aperture=Ø35mm, Accuracy: Class 0.5
PMC-SCCT-800A-40mA-A	L=2m, Aperture=80x50mm, Accuracy: Class 0.5
PMC-SCCT-1600A-40mA-A	L=2m, Aperture=130x55mm, Accuracy: Class 0.5



### Rogowski Coil

PMC-RC-400A-40mA-3P-100-PY-W-F	3-phase 400A/40mA Rogowski Coil, Aperture=Ø100mm
PMC-RC-1200A-40mA-3P-150-PY-W-F	3-phase 1200A/40mA Rogowski Coil, Aperture=Ø150mm
PMC-RC-2500A-40mA-3P-200-PY-W-F	3-phase 2500A/40mA Rogowski Coil, Aperture=Ø200mm
PMC-RC-5000A-40mA-3P-350-PY-W-F	3-phase 5000A/40mA Rogowski Coil, Aperture=Ø350mm

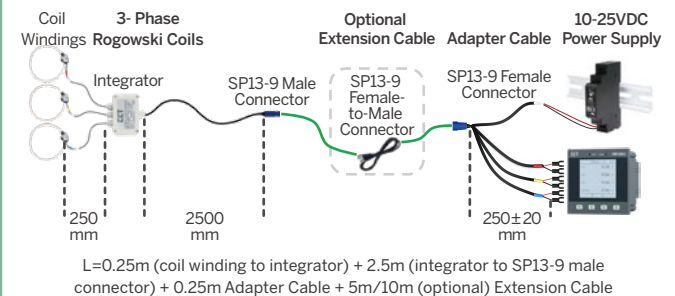

PMC-RC-400A-40mA-1P-100-PY-W-N	1-phase 400A/40mA Rogowski Coil, Aperture=Ø100mm
PMC-RC-1200A-40mA-1P-150-PY-W-N	1-phase 1200A/40mA Rogowski Coil, Aperture=Ø150mm
PMC-RC-2500A-40mA-1P-200-PY-W-N	1-phase 2500A/40mA Rogowski Coil, Aperture=Ø200mm
PMC-RC-5000A-40mA-1P-350-PY-W-N	1-phase 5000A/40mA Rogowski Coil, Aperture=Ø350mm

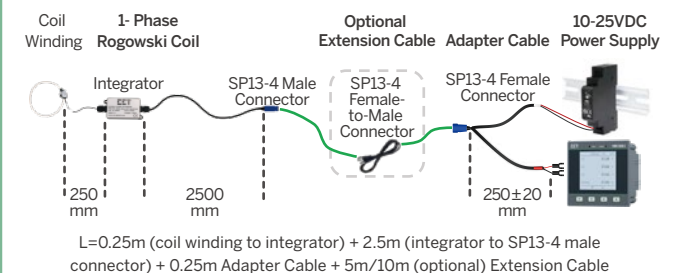

# Dimensions and Installations

(Unit: mm)

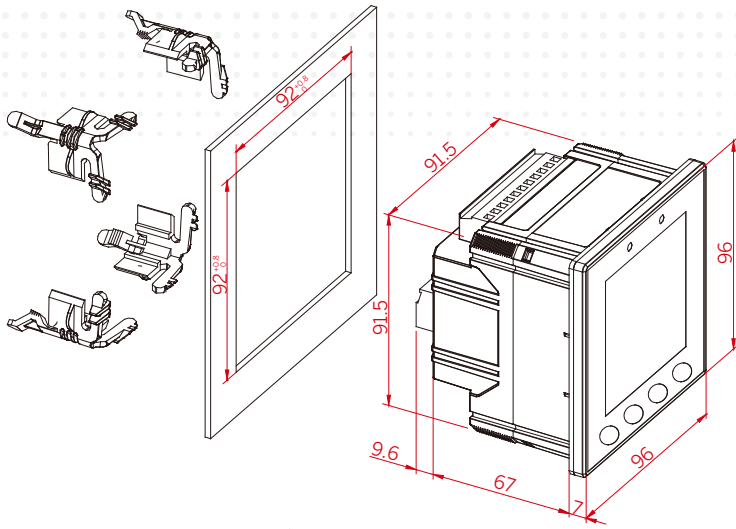

Panel Cutout Installation

# Rear Terminals

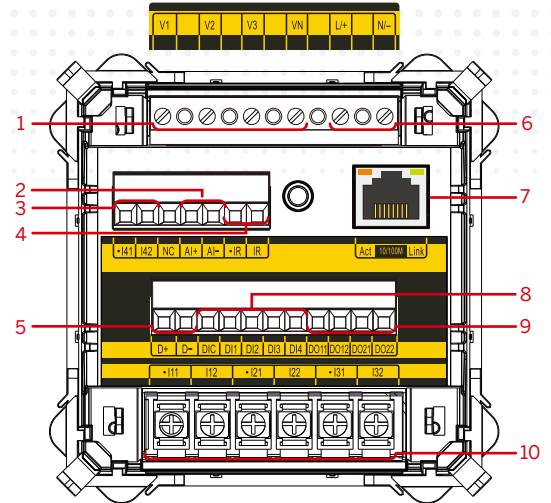

- |                         |  |
|-------------------------|--|
| 1 4xVoltage Input       | 6 Power Supply                             |
| 2 Optional Analog Input | 7 10Base-T/<br>100Base-TX<br>Ethernet Port |
| 3 Optional I4 Input     | 8 Digital Inputs                           |
| 4 Optional IR Input     | 9 Digital Outputs                          |
| 5 RS-485 Port           | 10 3xCurrent Input                         |

Email: [sales@cet-global.com](mailto:sales@cet-global.com)  
 Website: [www.cet-global.com](http://www.cet-global.com)

Copyright © CET Inc. All rights reserved.

Your Local Representative

